



**TECHNOLOGICAL AND INDUSTRIAL
SOLUTIONS**

■ **TC PNEUMATIC PRINTER**

- reciprocating unit to print codes, sell
by dates onto all substrates.
It works automatically on line
or manually off line and can be top,
bottom or side mounted.

TIFLEX
marquer le monde*

**MARKING
IDENTIFICATION, CODING**



* making an impression

Reciprocating unit to print codes, sell by dates... onto all substrates. It works automatically on line or manually off line and can be top, bottom or side mounted.

Running principle

A control box receives a signal from a detector and gives the instruction to the head to print.

Detector

Electrical or pneumatic, it detects the presence of the item to print.

Its choice is function of the process, the mechanical configuration and the item to print (volume, weight, fragility, etc...).

Control box

It can activate one or several printing heads.

The used input signal is pneumatic or electrical.

CBM boxes synchronize the blocking system of the item to print (continuous conveyor) and the printing head.

TC head

The settings of the contacts head/ink cartridge and head/item to print are very precise.

It is available in 2 sizes according to 3 sizes of type holder.

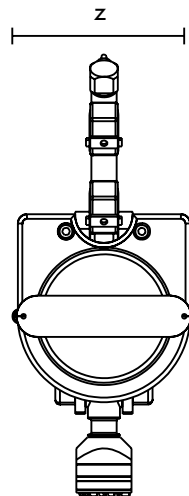
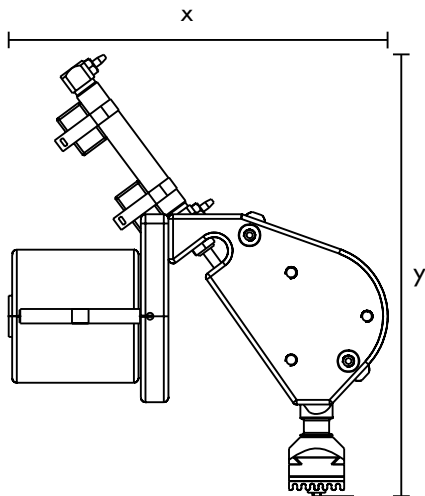

type holder size	measurements		
	x	y	z
24 x 24	165 mm	195	75 mm
24 x 35	165 mm	195	75 mm
24 x 48	181 mm	195	90 mm
maxi air pressure	2 bars		

Type holder

3 sizes are available : 24 x 24 mm, 24 x 35 mm and 24 x 48 mm.

It is covered with ribbed rubber AUTOCLIPS allowing a fast composition.

Type holders can be changed in seconds. Spare holders can be used to pre-set autoclips types

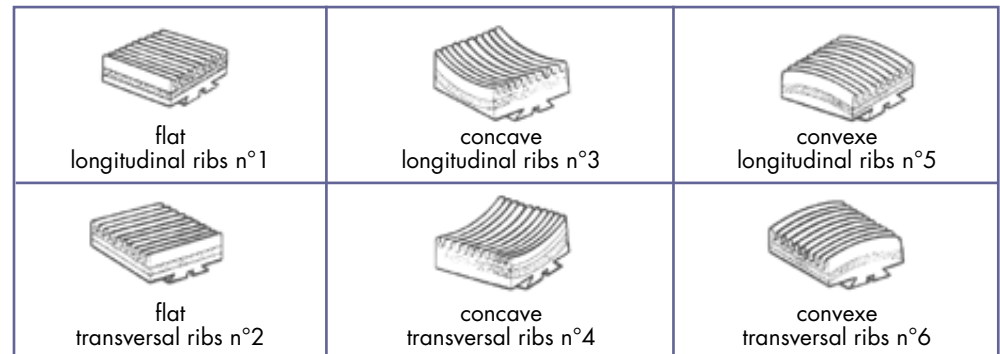

type holder size	maxi marking length	number of ribs	maxi marking width
24 x 24 (longitudinal or transversal ribs)	24 mm	6	21 mm
24 x 35 (longitudinal ribs)	35 mm	6	21 mm
24 x 35 (transversal ribs)	24 mm	9	32 mm
24 x 48 (longitudinal ribs)	48 mm	6	21 mm
24 x 48 (transversal ribs)	24 mm	12	43 mm

Autoclips characters (see our specific documentation)

On the AUTOCLIPS base of the type holders, characters and logos can be easily changed.
To obtain a sharp print and to speed the drying time we advise our diamond shaped type styles.

Inking

- Non porous substrates
A clean fast drying ink cartridge is fitted to the print head. Different ink qualities are available : CM 207, CM 4398, CM 4399, CM 300, CM 700, black / blue CM termochronic in order to control the sterilization, etc... (see relative documentation).
- Porous substrates
We propose two possibilities : pre-inked plastic inks disks or cartridges.

Mounting of the head

Two versatile XYZ mountings are available as presented hereunder.

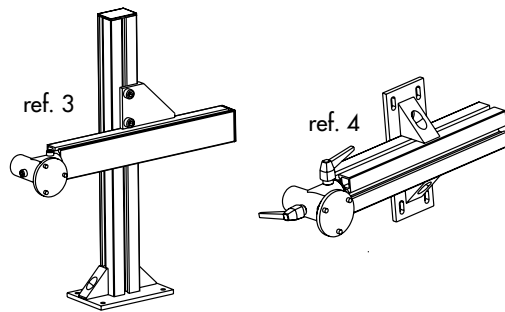

Bench model «bottom marking»

Unit made of aluminium profiles composed of a TC head, a control box T 202, an electrical detector and an item positioning setting.

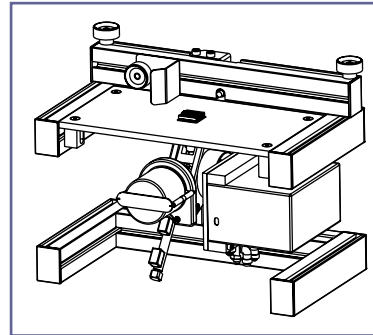

Selection table of the different units

unit	T 201	T 202
convoyor	alternative	alternative
speed	120 prints/mn	150 prints/mn
detector	pneumatic	electrical 220 V or 24 V AC-DC
minimum air pressure at the entry of the control box	4 bars	4 bars

